

Articulated Dump Truck



Specifications

Maximum Payload	30.9 tons (28 t)
Heaped Capacity	22.9 yd ³ (17.5 m ³)
Gross Power	385 hp (287 kW)

Features

- High powered, heavy-duty truck with powerful engine providing class leading performance and ability to go where others can't follow
- World class operator's environment
- One of the most fuel efficient trucks in the field
- Highest in class carrying capacity, which can be greatly increased with the addition of a tailgate
- Superior gradeability and higher top speeds increase production

WORKS FOR YOU.

SPECIFICATIONS

Engine

Engine	Cummins QSM11
Type	6 cylinder, in-line, four cycle, water cooled, turbocharged with air to air charge cooling, direct injection, electronic engine management
Piston Displacement	660 in ³ (10.8 liters)
Bore x Stroke	4.92 x 5.97 in (125 x 147 mm)
Gross Power	385 hp (287 kW) @ 1800 rpm
Net Power	333 hp (248 kW) @ 2100 rpm
Maximum Torque	1,309 lbf ft (1,775 Nm) @ 1400 rpm
Gross Power rated	SAE J1995 Jun 90
Engine Emissions	Meets USA EPA Tier 3/CARB MOH 40 CFR 89 Tier 3 and proposed EUNRMM (non-road mobile machinery directive) stage 3
Electrical	24 volt electric start. 70A alternator. Two 12 volt 175 Ah batteries
Air Cleaner	Dry-type air cleaner with safety element, automatic dust ejector and restriction indicator
Fan: Modulating fan reduces noise level and consumes engine power as required. Note: Net hp with fan clutch disengaged	
Altitude	Electronic derate 10,000 ft (3,048 m)

Transmission

ZF 6WG 310 RPC Fully automatic with manual over-ride

Assembly: Consists of a torque converter close-coupled to a counter shaft type gearbox with integral output transfer gearing. Automatic shifting throughout the range, with kick-down feature. Lockup in all forward gears. A torque-proportioning output differential transmits drive permanently to front and rear axles. This differential may be locked by the driver for use in difficult traction conditions.

Speeds mph (km/h)	Gear	Forward	Reverse
	1	3.4 (5.5)	3.4 (5.5)
	2	5.4 (8.6)	8.4 (13.4)
	3	8.4 (13.4)	19.0 (30.7)
	4	12.9 (20.8)	
	5	19.0 (30.7)	
	6	31.3 (50.4)	

Axles

Heavy duty axles with fully floating axle shafts and outboard planetary reduction gearing. The three axles are in permanent all-wheel drive (6x6) with a differential coupling between the front and rear axles. All three axles also have hydraulically actuated multiplate transverse diff-lock differentials for 100% cross-axle lock up. The inter-axle and cross-axle diff locks are controlled by the operator, and can be actuated when required in poor traction conditions.

Differential ratio	3.875 : 1
Planetary reduction	5.71 : 1
Overall Drivetrain reduction	22.12 : 1

Tires and Wheels

Tires	Standard 23.5. Optional 750/65
Rims	Standard 25x19.50. For optional tire, 25x22.00
Wheels	3-piece earth mover rims with 12 stud fixing



Suspension

Front	Fully independent suspension and wheel movement is provided by a double wishbone design. This is coupled with 4 x hydraulic dampers/coil over springs.
Rear	Each axle is coupled to the frame by three rubber-bushed links with lateral restraint by a transverse link. Pivoting inter-axle balance beams equalise load on each rear axle. Suspension movement is cushioned by rubber/metal laminated compression units between each axle and underside of balance beam ends. Pivot points on leading and trailing links are rubber-bushed and maintenance-free.

Steering

Hydrostatic power steering by two double-acting cushioned steering cylinders with pressure supplied by a variable displacement / load sensing piston pump. An audible alarm and warning light indicates should the second system activate.

Steering angle to either side	45°
Lock to lock turns, steering wheel	4
System pressure	3 500 lbf/in ² (241 bar)
SAE Turning Radius	27-9 ft/ins (8,470 mm)
Clearing Radius	29-4 ft/ins (8,950 mm)

Frame

Front and rear frames are all-welded high grade steel fabrications with rectangular box-section beams forming the main side and cross members. Inter-frame oscillation is provided by a large diameter cylindrical coupling which houses nylon bushings. Frames articulated 45° to either side for steering by means of two widely-spaced pivot pins in back-to-back sealed taper roller bearings.

Body

All-welded construction, fabricated from high hardness (min 360 BHN) 145 000 lbf/in² (1,000 Mpa) yield strength steel. Dual slope tailchute improves material ejection from body.

Plate thickness:	Floor and tailchute	0.55 in (14.0 mm)
	Sides	0.47 in (12.0 mm)
	Front	0.31 in (8.0 mm)
Volume:	Struck	18.0 yd ³ (13.8 m ³)
	Heaped 2:1 (SAE)	22.9 yd ³ (0)

Hoist

Two single-stage, double-acting hoist cylinders, cushioned at the base end. Variable displacement / load sensing piston pump driven from power take-off on transmission. Full flow return line filtration. Full electro-hydraulic hoist control, with electronic detent in power down.

System pressure	3,200 lbf/in ² (220 bar)	Raise (loaded)	12 seconds
Pump output flow rate	77.6 gal/min (4.9 liter/sec)	Lower	7.5 seconds



SPECIFICATIONS

TA300

Capacities

Fuel Tank	103 gal (390 liters)
Hydraulic System (Steering & Body)	53.4 gal (202 liters)
Engine Crankcase	10.8 gal (41 liters)
Cooling System	14.3 gal (54 liters)
Transmission (inc filters and cooler)	15.9 gal (60 liters)
Differential – Front & Rear (each)	5.5 gal (21 liters)
Differential - Centre	6.0 gal (23 liters)
Planetaries – (each)	2.0 gal (7.5 liters)

STANDARD EQUIPMENT

General

Articulation and Oscillation Lock	Modulating Cooling Fans
Battery Master Switch	Mudflaps at Front and Centre
Body Prop	Neutral Start Interlock
Brakes Fully Hydraulic Dual Circuit System	Pivot Protection Guard
Diagnostic Pressure Test Points	Rear Light Guards
Inter axle and Cross axle Differential Locks	Reverse Alarm Audible J994
Electronic Assisted Body Hoist Control	Secondary Steering
Engine/Transmission/Hydraulic electronic management systems	Security Kit
Engine Underguard	Tilting Cab for Maintenance
Exhaust Muffler	Tow Points, Front and Rear
Handrails on Fenders	Transmission Downshift Inhibitor
Headlamp Guards	Independent Suspension
Horn, Electric 117db	Transmission Sump Guard
Hydraulic Diagnostic Facility RS232	Tire Inflation Nitrogen
Hydraulic Filter Restriction Indicator	2 stage manual/automatic Engine Brake

Warning Lights & Audible Alarms

Alternator Charging	Front Brake Accumulator Pressure
Body Up	Headlight High Beam
Engine maintenance monitor	Transmission gear attained
Wait to start (not used)	Low Fuel
Differential lock	Parking Brake
Direction Indicators	Rear Brake Accumulator Pressure
Engine Air Filter Change	Secondary Steering
Engine Brake	Transmission check
Engine 'CHECK'	Transmission high oil temperature
Engine 'STOP'	Transmission Retarder (when option is fitted)

Brakes

All hydraulic braking systems with multi-plate sealed and oil cooled brake packs at each wheel. Independent circuits for front and rear brake systems.	
Parking	Spring-applied, hydraulic-released disc on rear driveline
Secondary	Secondary brake control actuates service and parking brakes
Retarder	Engine compression brake is standard.

Cab and Operator

Air Conditioning	ROPS/FOPS Protection ISO3471/3449 SAE J1040 Apr 88/J386
Air Filter Restriction Indicator	Seat Belts Retractable J386
Auxiliary power outlets 12V & 24V	Seat, Operator, air suspension, high back, headrest and adjustable armrests
CD/Radio Cassette	Seat Passenger
Coat Hook	Steering Wheel, tilt/telescopic
Engine/Transmission/Hydraulic Diagnostic Facility	Storage Compartment
Heater and Demister	Sun Visor (Internal)
Insulation, Thermal and Acoustic	Tinted Glass
Interior Light	Transmission Visual Display Unit
Mirror Rear View (4)	Window Protection Grille, rear
Mug Holder	Wiper and Washer, front and rear windows

Reversing Safety camera/monitor

Gauges

Transmission Sump oil Temperature	Speedometer/Digital Odometer/Trip meter
Engine Coolant Temperature	System Voltage
Fuel Level	Tachometer
Hour meter	Transmission Converter Oil Temp.

Lights

Direction and Hazard Warning Indicators (LED on rear)	Side and Tail (LED)
Front Working Lights, Roof Mounted	2 halogen headlamps dipped beam
Reverse Warning	2 halogen headlamps main beam

WORKS FOR YOU.

DIMENSIONS

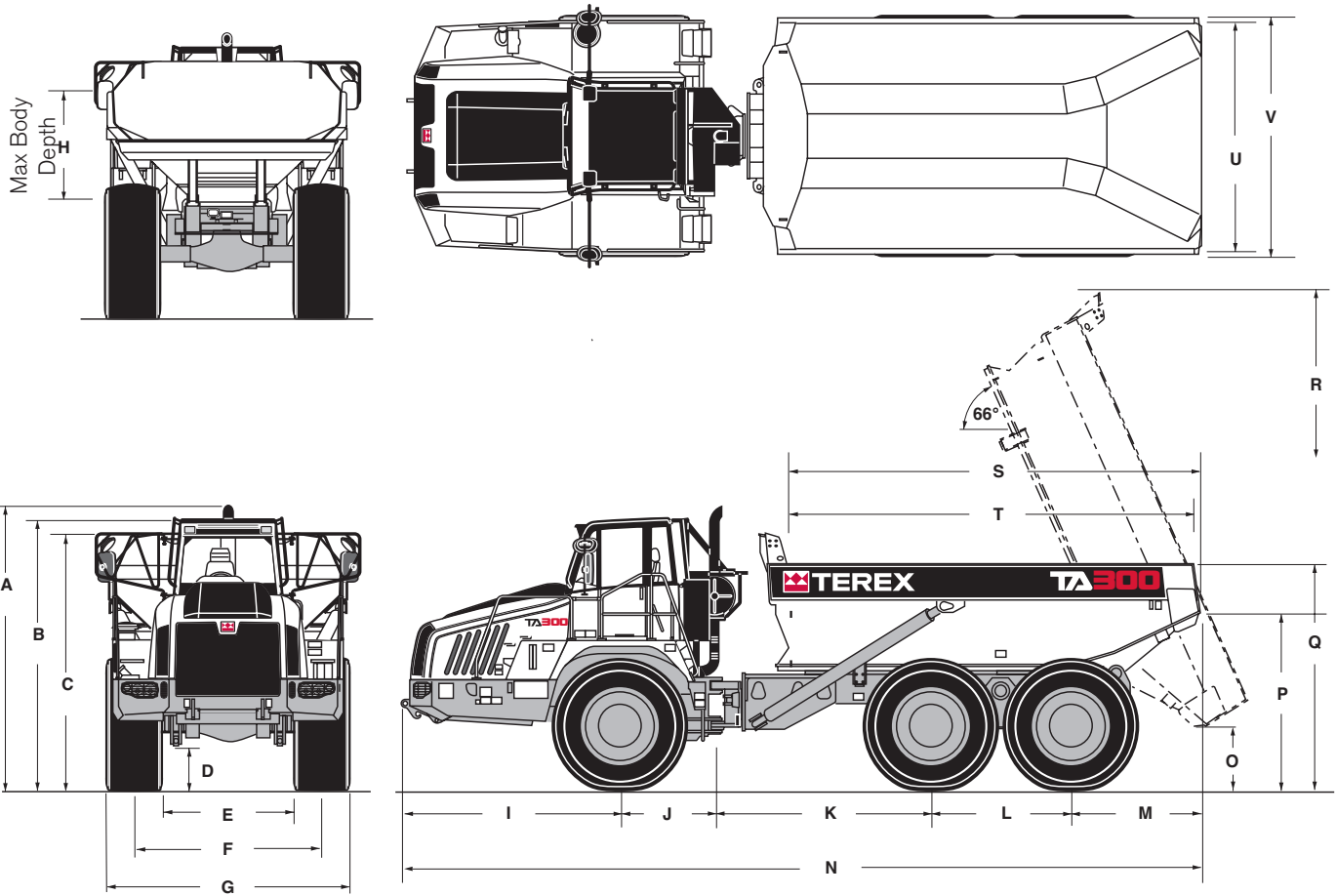

Weights

Net Distribution

Vehicle, Net	22,485 kg (49,573 lb)	Payload	28,000 kg (61,730 lb)
Bogie Axle		Bogie Axle	
Trailing	5,315 kg (11,718 lb)	Leading	5,417 kg (11,942 lb)
Front Axle	11,753 kg (25,913 lb)		

Gross Distribution

Vehicle Gross	50,485 lb (111,303 Kg)	Body	4,400 lb (9,700 Kg)
Front Axle	16,821 lb (37,086 Kg)	Hoists, pair	530 lb (1,170 Kg)
Bogie Axle		Bare	
Leading	16,740 lb (36,904 Kg)	Chassis	17,555 lb (38,703 Kg)

Ground Pressure

These figures are at 15% shrinkage of unloaded radius and specified weights using

Tires 29.5 R25

Unloaded

Front	17.2 Psi	112 kPa
Rear	7.8 Psi	54 kPa

Loaded

Front	24.6 Psi	170 kPa
Rear	24.6 Psi	170 kPa

Dimensions

Standard Unit	ft-in	mm
A	11-3	3,450
B	11-2	3,420
C	10-10	3,325
D	1-6	405
E	5-3	1,580
F	7-2	2,200
G	9-6	2,895
H	4-9	1,445
I	7-9	2,400
J	4-4	1,310
K	9-8	2,945
L	5-6	1,690
M	4-9	1,490
N	32-0	9,755
O	2-3	725
P	7-2	2,175
Q	9-6	2,895
R	20-0	6,110
S	16-5	5,010
T	16-2	4,920
U	8-10	2,685
V	9-6	2,895



GRADEABILITY

TA300

Unit equipped with 23.5 R25 tires. Graphs based on 2% Rolling Resistance.

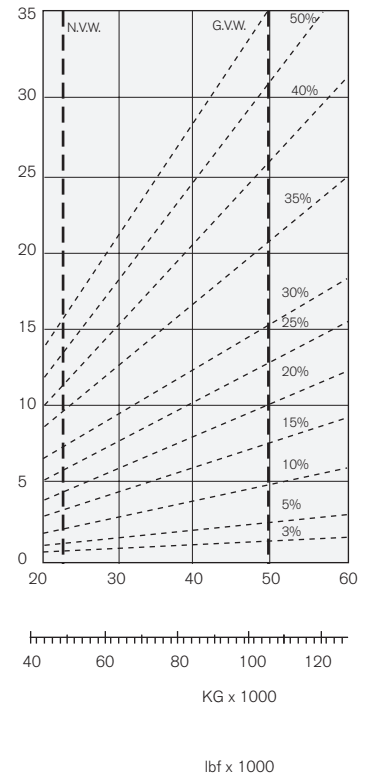
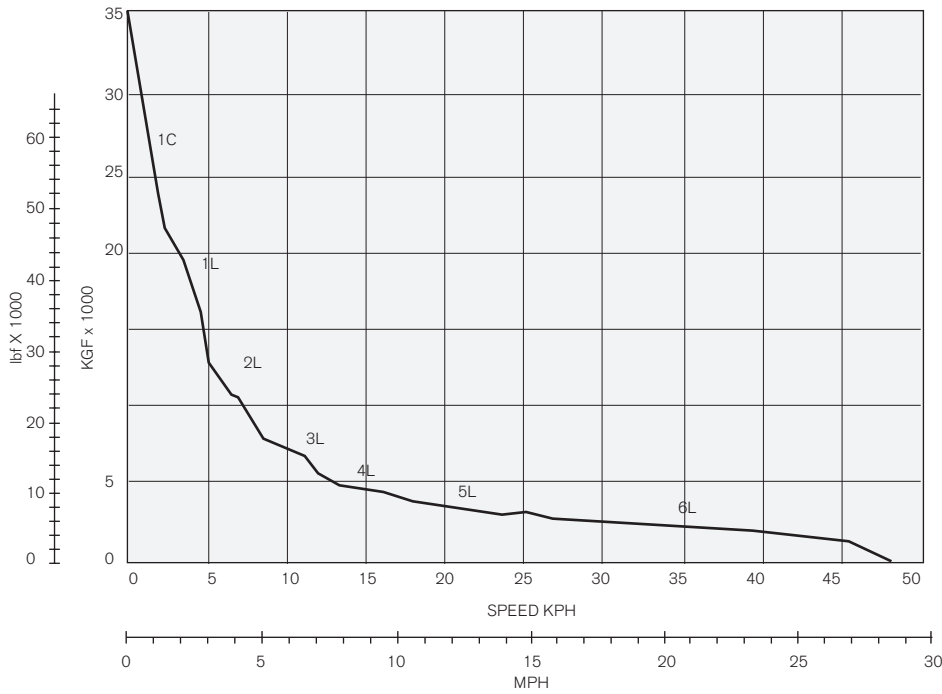

TOTAL % RESISTANCE Rolling plus Grade

RETARDATION

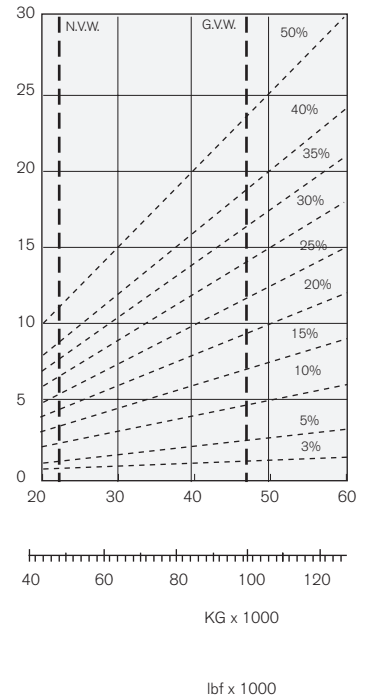
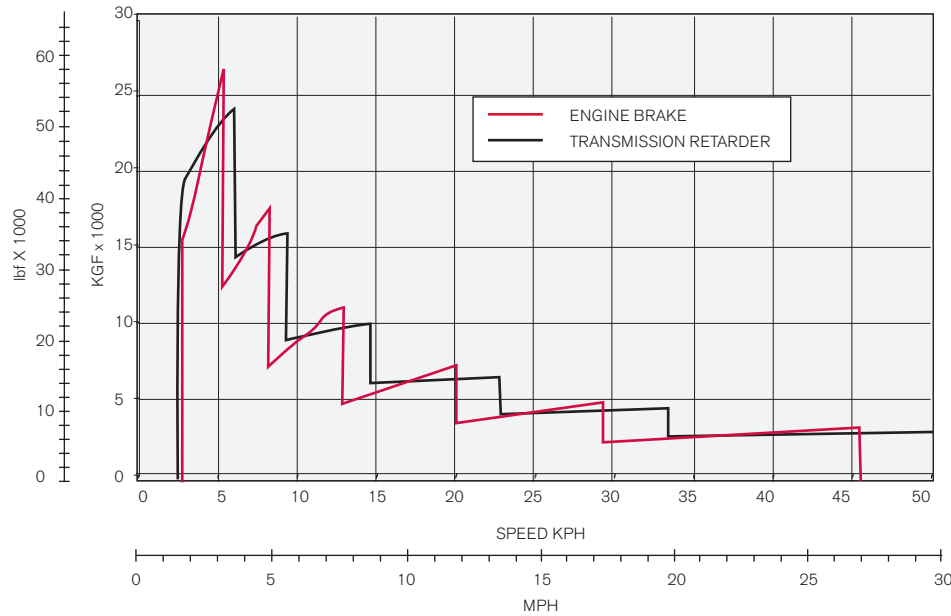

TOTAL % RESISTANCE Rolling minus Grade

Instructions: From intersection of vehicle weight with percentage resistance line read across to determine maximum gear attainable, and then downwards for speed.

WORKS FOR YOU.

OPTIONAL EQUIPMENT

Body Options

Body Side Extensions	Spillguard Extension
Heated Body	Top Tailgate
Liner Plates	

Lights

Beacon Flashing	Rear Working Lights, Roof Mounted
Fog Rear	Reverse Flashing

Mirrors

Mirror Front Mounted	Mirrors Heated
Mirror with Wide Angle	

Other Options

Automatic Lubrication	Payload Monitoring System
Fire Extinguisher	Seat Heated
First Aid Kit	Transmission Retarder
Hydraulic Oil Cooler	Tool Kit
Parking Brake Guard	

terex.com

Effective Date: April 2010. Product specifications and prices are subject to change without notice or obligation. The photographs and/or drawings in this document are for illustrative purposes only. Refer to the appropriate Operator's Manual for instructions on the proper use of this equipment. Failure to follow the appropriate Operator's Manual when using our equipment or to otherwise act irresponsibly may result in serious injury or death. The only warranty applicable to our equipment is the standard written warranty applicable to the particular product and sale and Terex makes no other warranty, express or implied. Products and services listed may be trademarks, service marks, or trade names of Terex Corporation and/or its subsidiaries in the USA and other countries. All rights are reserved. Terex is a registered trademark of Terex Corporation in the USA and many other countries. © 2010 Terex Corporation.

8800 Rostin Road, Southaven, MS 38671 USA
1.888.90.TEREX (83739)



WORKS FOR YOU.

TA300 0410 PN1090912